

V1082 FLOOR MOUNTED DOOR STOP

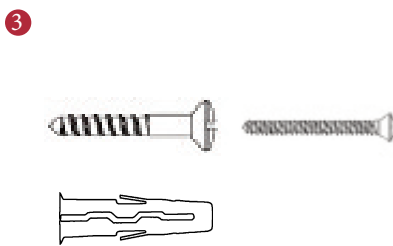
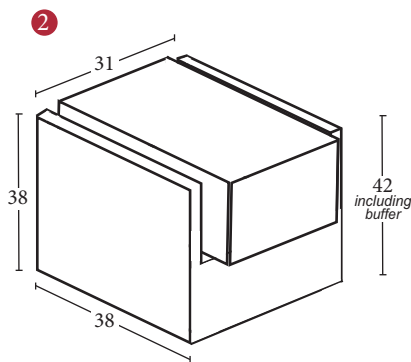
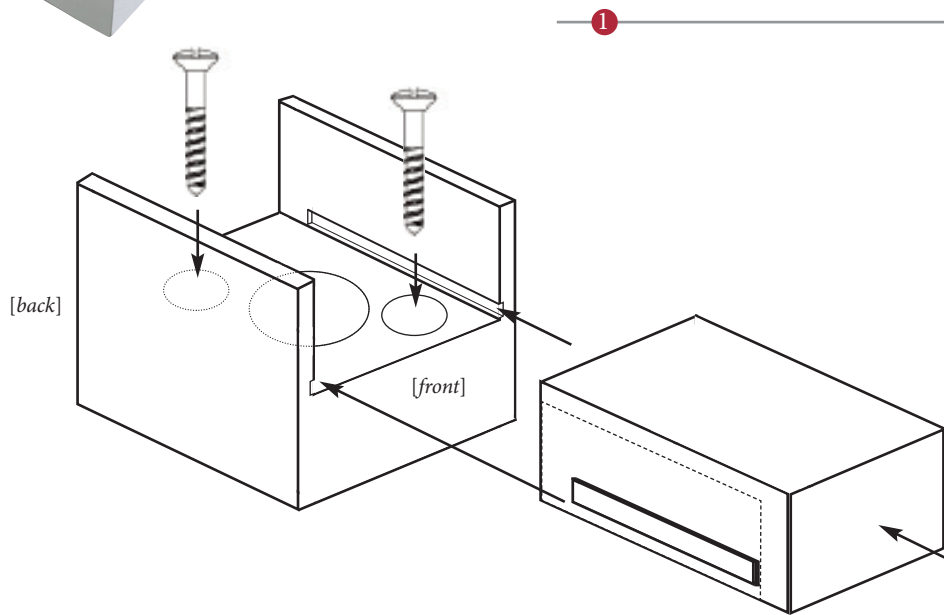
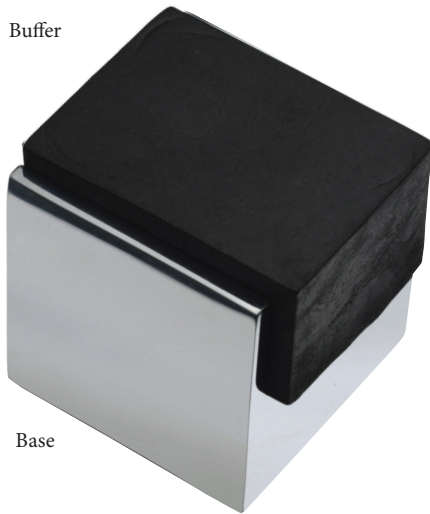

FITTING
Floor Mounted

- 1 Position base part behind door at a point more than half way along from the hinged edge and determine where to drill fixing holes as desired, ensuring that the [front] is facing outwards, that being towards the back of the opened door
- 2 Mark out holes for the two fixings (note: plastic plugs are provided for where floors are concrete)
- 3 Affix the base part through the base holes as above indicated using the wood screws provided
- 4 With base secured, push on the buffer into the side sleeves as shown above, (note: when buffer is lined up with the base [back] it is fully inserted), leaving a lip to the front as indicated that will safely 'stop' the door at that point
- 5 Test

Overview

- | | | | |
|---------------------------------------|------------------------------------|---|------------------|
| ① Floor Mounted Door Stop illustrated | ② (General dimensions of assembly) | ③ Supplied with:
2 x wood screws
1x starter screw | 2 x plastic plug |
|---------------------------------------|------------------------------------|---|------------------|

 **M Marcus Ltd., Dudley**

Material	Date	Product Code	Description	Sizes shown are in mm and approximate. We reserve the right to amend where necessary and without any prior notice.
Solid Forged Brass	10 Sept 2019	V1082	Door Stop	