

V1080 FLOOR MOUNTED DOOR STOP

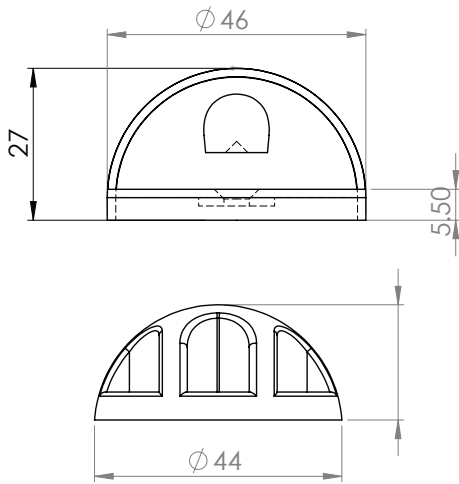

Buffer

1

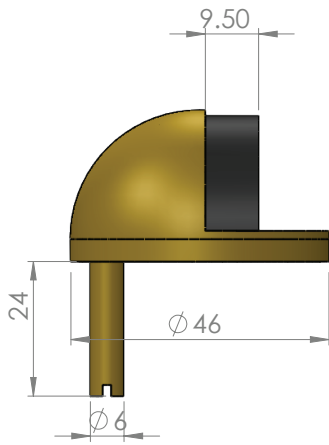

FLOOR MOUNTING TEMPLATE MUST be printed off at full scale when using this template

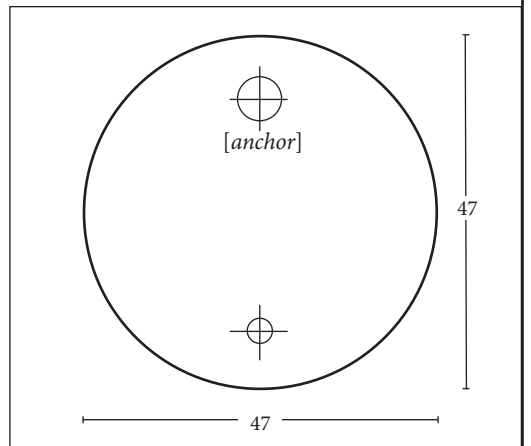

FITTING

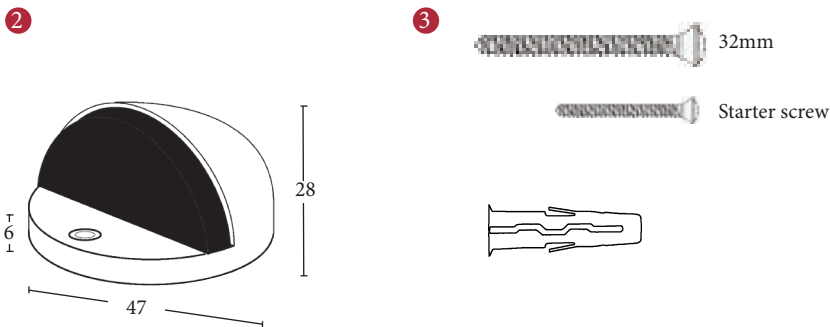

- 1 Position base part behind door at a point more than half way along from the hinged edge and determine where to drill fixing holes as desired, there drill a 6mm hole for the affixed [anchor] and a 3mm drilled hole (or larger to allow for rawplug if you have concrete floors) utilising the template as given above.
- 2 To assemble: Locate the anchor point and insert.
- 3 Next affix the door stop through the assigned hole using the 32mm screw provided (as illustrated).
- 4 Tighten and test

Overview

- 1 Door Stop illustrated with floor template
 - 2 General dimensions of assembly
 - 3 Supplied with:
1x 32mm screw
1x starter screw
- 1x plastic rawplug

 M Marcus Ltd., Dudley

Product Code

V1080

Material

Solid Brass

Available in all Heritage Brass finishes.

Sizes shown are in mm and approximate. We reserve the right to amend where necessary and without any prior notice.