

K1270 EXTERNAL DOOR HARDWARE

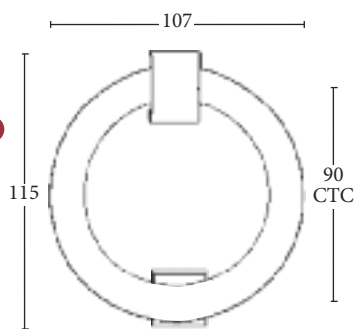
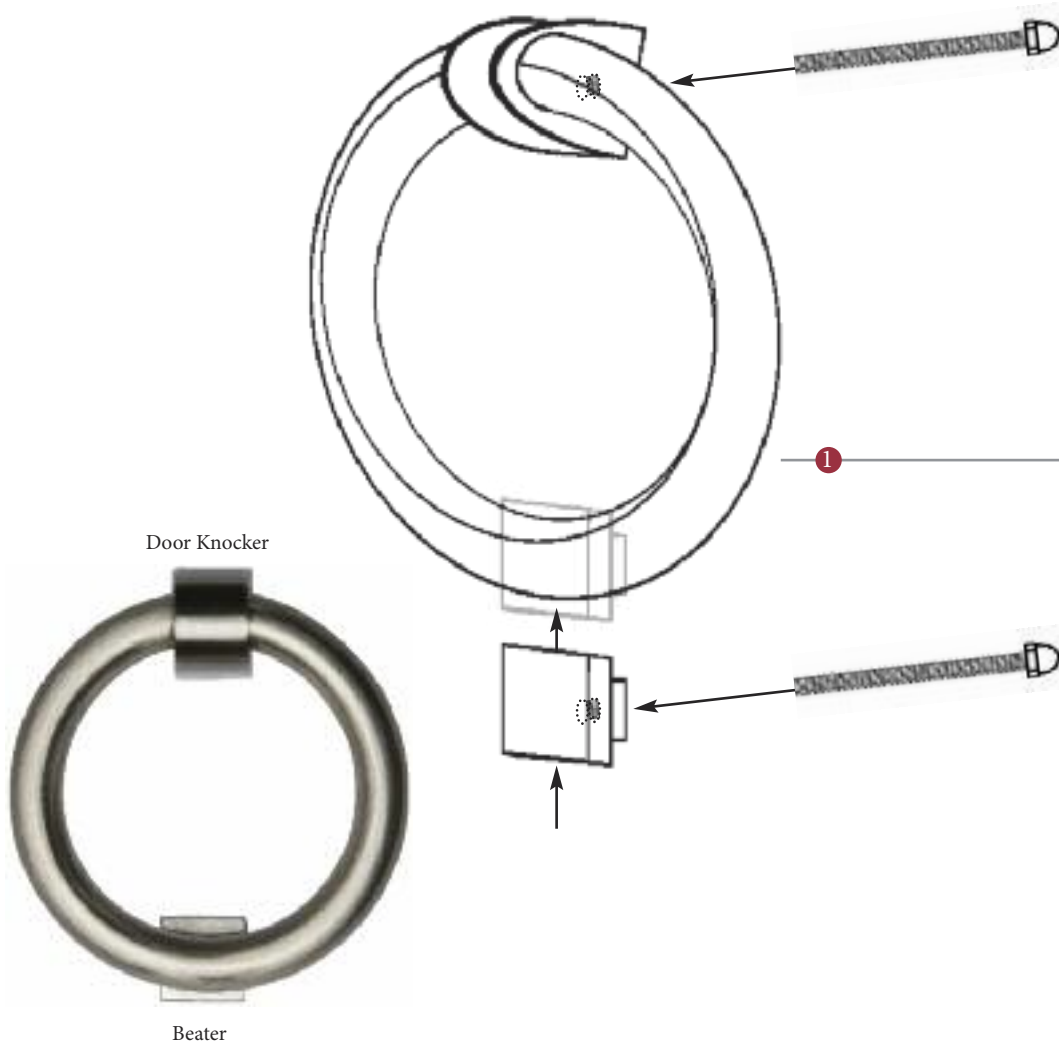

FITTING

- 1 Position Knocker assembly centrally on door and determine where to drill uppermost knocker fixing hole.
- 2 Drill a 5mm hole through the door.
- 3 From the centre of that first position measure 90mm straight downwards and drill a 5mm hole through the door at that point
- 4 Utilising the top drill hole: Affix the knocker through the backplate using one of the threaded back bolts supplied
- 5 Utilising the lower drill hole: Affix the beater plate to the door using the remaining threaded back bolt supplied
- 6 Tighten and test

Overview

① Door Knocker and Beater fixings illustrated

② (General Dimensions of Door Knocker and Beater)

③ Supplied with: 2x 65mm threaded back bolt

M Marcus Ltd., Dudley

Material	Date	Product Code	Description	Sizes shown are in mm and approximate. We reserve the right to amend where necessary and without any prior notice.
Solid Forged Brass	10 Sept 2019	K1270	Door Knocker	